



Installation Manual

Trailer Edition
SLXi DRC

Single Temperature Systems

Revision B

May 2018

TK 56403-2-IM-EN

TRANE
TECHNOLOGIES

Introduction

This manual was written to assist with the installation of the Thermo King refrigeration systems onto Domestic Refrigerated Containers (DRC) and are specifically designed and built for refrigerated applications.

Due to its complexity, you should not attempt this installation unless you:

- Are an experienced mechanic
- Can safely lift 34 kilos (75 lbs.)
- Are certified or trained in the repair and maintenance of diesel powered refrigeration systems
- Have a basic understanding of electricity and electrical wiring
- Have the necessary tools and equipment to complete the installation

This manual is published for informational purposes only. Thermo King makes no representations warranties express or implied, with respect to the information recommendations and descriptions contained herein. Information provided should not be regarded as all-inclusive or covering all contingencies. If further information is required, Thermo King Corporation Service Department should be consulted.

Thermo King's warranty shall not apply to any equipment which has been "so installed, maintained, repaired or altered as, in the manufacturer's judgment, to affect its integrity."

Manufacturer shall have no liability to any person or entity for any personal injury, property damage or any other direct, indirect, special, or consequential damages whatsoever, arising out of the use of this manual or any information, recommendations or descriptions contained herein. The procedures described herein should only be undertaken by suitably qualified personnel. Failure to implement these procedures correctly may cause damage to the Thermo King unit or other property or personal injury.

Revision History

Revision A	(07/17) Released new manual format.
Revision B	(05/18) Updated Mounting Bolt dimensions

Customer Satisfaction Survey

Let your voice be heard!

Your feedback will help improve our manuals. The survey is accessible through any internet-connected device with a web browser.

Scan the Quick Response (QR) code or click or type the web address https://tranetechnologies.iad1.qualtrics.com/jfe/form/SV_2octfSHoUJxsk6x?Q_CHL=qr&Q_JFE=qdg to complete the survey.



Table of Contents

Safety Precautions	6
Danger, Warning, Caution, and Notice	6
General Practices	6
Battery Installation and Cable Routing	7
Refrigerant Hazards	8
Refrigerant Oil Hazards.....	9
First Aid.....	9
Installation Summary	11
Trailer Requirements	12
Front Wall Requirements	12
Unit Mounting Hardware	12
Unit Dimensions.....	12
Fuel Tank Mounting	12
King Pin Dimensions	12
Swing Radius Clearance.....	12
Evaporator Opening Requirements	13
Mounting Hardware Requirements	15
Mounting Bolts	15
Mounting Bolt Specifications	15
Lifting Bar Dimensions	16
Required Tools for Installation	18
Installation Components – Domestic Refrigerated Container (DRC) Applications	20
Uncrating the Unit	22
Installing the Foam Insulation	23
Installing the Unit	24
Installing Drain Hoses and Coolant Overflow Hose – DRC Applications	25
Drain and Overflow Hose Installation	25
CargoWatch Installation	26
Sensor Location Recommendations	26
Connecting the Sensors	26
Additional Sensor Connection Procedure.....	26
Installing the Fuel lines – DRC Applications	28
Important Installation Requirements.....	28

Fuel System Fittings	28
Fuel Line Installation	31
Installing the Fuel Tank - DRC Applications	33
Installing the UFLS Harness – DRC Applications.....	35
“Solid State” Ultrasonic Fuel Level Sensor (UFLS).....	35
Interconnect Harness Installation and Routing.....	35
UFLS Harness Connections	36
Programming the Controller.....	37
Programming the SR-3 Controller for Fuel Level.....	37
Connecting the Battery	38
External Device Connection with LVD.....	39
General Information	39
The LVD Switch.....	39
Preparing the Unit for device connection.....	40
Connecting External devices to the LVD Harness	41
UNIT CHECK LIST	43

Safety Precautions

Danger, Warning, Caution, and Notice

Thermo King® recommends that all service be performed by a Thermo King dealer and to be aware of several general safety practices.

Safety advisories appear throughout this manual as required (refer to examples below). Your personal safety and the proper operation of this unit depend upon the strict observance of these precautions.

⚠ DANGER

Example!

Indicates an imminently hazardous situation which, if not avoided, will result in death or serious injury.

⚠ WARNING

Example!

Indicates a potentially hazardous situation which, if not avoided, could result in death or serious injury.

⚠ CAUTION

Example!

Indicates a potentially hazardous situation which, if not avoided, could result in minor or moderate injury and unsafe practices.

NOTICE

Example!

Indicates a situation that could result in equipment or property-damage only accidents.

General Practices

⚠ DANGER

Hazard of Explosion!

Never apply heat to a sealed refrigeration system or container. Heat increases internal pressure, which might cause an explosion resulting in death or serious injury.

⚠ DANGER

Hazardous Gases!

Refrigerant in the presence of an open flame, spark, or electrical short produces toxic gases that are severe respiratory irritants which can cause serious injury or possible death.

⚠ DANGER

Risk of Injury!

Keep your hands, clothing, and tools clear of fans and/or belts when working on a unit that is running or when opening or closing compressor service valves. Loose clothing might entangle moving pulleys or belts, causing serious injury or possible death.

⚠ DANGER

Refrigerant Vapor Hazard!

Do not inhale refrigerant. Use caution when working with refrigerant or a refrigeration system in any confined area with a limited air supply. Refrigerant displaces air and can cause oxygen depletion, resulting in suffocation and possible death.

⚠ DANGER**Confined Space Hazards!**

Avoid engine operation in confined spaces and areas or circumstances where fumes from the engine could become trapped and cause serious injury or death.

⚠ WARNING**Hazard of Explosion!**

Never close the compressor discharge service valve when the unit is operating. Never operate the unit with the discharge valve closed (front seated). This condition increases internal pressure, which can cause an explosion.

⚠ WARNING**Proper Equipment Condition!**

Gauge manifold hoses must be in good condition before using them. Never let them come in contact with moving belts, fans, pulleys or hot surfaces. Defective gauge equipment can damage components or cause serious injury.

⚠ WARNING**Personal Protective Equipment (PPE) Required!**

Always wear goggles or safety glasses when working on a unit. Refrigerant liquid, oil, and battery acid can permanently damage your eyes. See "First Aid".

⚠ WARNING**Equipment Damage and Risk of Injury!**

Never drill holes into the unit unless instructed by Thermo King. Holes drilled into high voltage cables could cause an electrical fire, severe personal injury, or even death.

⚠ WARNING**Risk of Injury!**

When using ladders to install or service refrigeration systems, always observe the ladder manufacturer's safety labels and warnings. A work platform or scaffolding is the recommended method for installations and servicing.

⚠ CAUTION**Sharp Edges!**

Exposed coil fins can cause lacerations. Service work on the evaporator or condenser coils is best left to a certified Thermo King technician.

NOTICE**Equipment Damage!**

All mounting bolts must be the correct length for their applications and torqued to specification. Incorrect bolt lengths and improper torque specifications can damage equipment.

Battery Installation and Cable Routing**⚠ WARNING****Hazard of Explosion!**

An improperly installed battery could result in a fire, explosion, or injury. A Thermo King approved battery must be installed and properly secured to the battery tray.



Safety Precautions

⚠ WARNING

Hazard of Explosion!

Improperly installed battery cables could result in a fire, explosion, or injury. Battery cables must be installed, routed, and secured properly to prevent them from rubbing, chaffing, or making contact with hot, sharp, or rotating components.

⚠ WARNING

Fire Hazard!

Do not attach fuel lines to battery cables or electrical harnesses. This has the potential to cause a fire and could cause serious injury or death.

⚠ WARNING

Personal Protective Equipment (PPE) Required!

A battery can be dangerous. A battery contains a flammable gas that can ignite or explode. A battery stores enough electricity to burn you if it discharges quickly. A battery contains battery acid that can burn you. Always wear goggles or safety glasses and personal protective equipment when working with a battery. If you get battery acid on you, immediately flush it with water and get medical attention.

⚠ WARNING

Hazard of Explosion!

Always cover battery terminals to prevent them from making contact with metal components during battery installation. Battery terminals grounding against metal could cause the battery to explode.

⚠ CAUTION

Hazardous Service Procedures!

Set all unit electrical controls to the OFF position before connecting battery cables to the battery to prevent unit from starting unexpectedly and causing personal injury.

NOTICE

Equipment Damage!

Do not connect other manufacturer's equipment or accessories to the unit unless approved by Thermo King. Failure to do so can result in severe damage to equipment and void the warranty.

Refrigerant Hazards

⚠ DANGER

Hazardous Pressures!

Always store refrigerant in proper containers, out of direct sunlight and away from intense heat. Heat increases pressure inside storage containers, which can cause them to burst and could result in severe personal injury.

⚠ DANGER

Combustible Hazard!

Do not use oxygen (O₂) or compressed air for leak testing. Oxygen mixed with refrigerant is combustible.

⚠ WARNING

Hazardous Gases!

Do not use a Halide torch. When a flame comes in contact with refrigerant, toxic gases are produced. These gases can cause suffocation, even death.

⚠ WARNING**Personal Protective Equipment (PPE) Required!**

Refrigerant in a liquid state evaporates rapidly when exposed to the atmosphere, freezing anything it contacts. Wear butyl lined gloves and other clothing and eye wear when handling refrigerant to help prevent frostbite.

NOTICE**Equipment Damage!**

When being transferred, refrigerant must be in liquid state to avoid possible equipment damage.

Refrigerant Oil Hazards**⚠ WARNING****Personal Protective Equipment (PPE) Required!**

Protect your eyes from contact with refrigerant oil. The oil can cause serious eye injuries. Protect skin and clothing from prolonged or repeated contact with refrigerant oil. To prevent irritation, wash your hands and clothing thoroughly after handling the oil. Rubber gloves are recommended.

NOTICE**Equipment Damage!**

Use the correct oil in Thermo King systems to avoid damaging equipment and nullifying its warranty.

NOTICE**Equipment Damage!**

Do not mix refrigerant oils. Mixing incompatible oils will damage the system.

NOTICE**Equipment Damage!**

Use dedicated refrigeration equipment to prevent contaminating refrigeration systems with the wrong type of oil or refrigerant.

NOTICE**System Contamination!**

Do not expose the refrigerant oil to the air any longer than necessary. Store refrigerant oil in an approved sealed container to avoid moisture contamination. The oil will absorb moisture, which results in much longer evacuation times and possible system contamination.

NOTICE**Material Damage!**

Wipe up spills immediately. Refrigerant oil can damage paints and rubber materials.

First Aid**REFRIGERANT**

- **Eyes:** For contact with liquid, immediately flush eyes with large amounts of water and get prompt medical attention.
- **Skin:** Flush area with large amounts of warm water. Do not apply heat. Remove contaminated clothing and shoes. Wrap burns with dry, sterile, bulky dressing to protect from infection. Get prompt medical attention. Wash contaminated clothing before reuse.



Safety Precautions

- **Inhalation:** Move victim to fresh air and use Cardio Pulmonary Resuscitation (CPR) or mouth-to-mouth resuscitation to restore breathing, if necessary. Stay with victim until emergency personnel arrive.
- **Frost Bite:** In the event of frost bite, the objectives of First Aid are to protect the frozen area from further injury, warm the affected area rapidly, and to maintain respiration.

REFRIGERANT OIL

- **Eyes:** Immediately flush with large amounts of water for at least 15 minutes. Get prompt medical attention.
- **Skin:** Remove contaminated clothing. Wash thoroughly with soap and water. Get medical attention if irritation persists.
- **Inhalation:** Move victim to fresh air and use Cardio Pulmonary Resuscitation (CPR) or mouth-to-mouth resuscitation to restore breathing, if necessary. Stay with victim until emergency personnel arrive.
- **Ingestion:** Do not induce vomiting. Immediately contact local poison control center or physician.

ENGINE COOLANT

- **Eyes:** Immediately flush with large amounts of water for at least 15 minutes. Get prompt medical attention.
- **Skin:** Remove contaminated clothing. Wash thoroughly with soap and water. Get medical attention if irritation persists.
- **Ingestion:** Do not induce vomiting. Immediately contact local poison control center or physician.

BATTERY ACID

- **Eyes:** Immediately flush with large amounts of water for at least 15 minutes. Get prompt medical attention. Wash skin with soap and water.

ELECTRICAL SHOCK

Take IMMEDIATE action after a person has received an electrical shock. Get quick medical assistance, if possible.

The source of the shock must be quickly stopped, by either shutting off the power or removing the victim. If the power cannot be shut off, the wire should be cut with a non-conductive tool, such as a wood-handle axe or thickly insulated cable cutters. Rescuers should wear insulated gloves and safety glasses, and avoid looking at wires being cut. The ensuing flash can cause burns and blindness.

If the victim must be removed from a live circuit, pull the victim away with a non-conductive material. Use wood, rope, a belt or coat to pull or push the victim away from the current. DO NOT TOUCH the victim. You will receive a shock from current flowing through the victim's body. After separating the victim from power source, immediately check for signs of a pulse and respiration. If no pulse is present, start Cardio Pulmonary Resuscitation (CPR). If a pulse is present, respiration might be restored by using mouth-to-mouth resuscitation. Call for emergency medical assistance.

ASPHYXIATION

Move victim to fresh air and use Cardio Pulmonary Resuscitation (CPR) or mouth-to-mouth resuscitation to restore breathing, if necessary. Stay with victim until emergency personnel arrive.

Installation Summary

SLXi installs the same as a Precedent unit with the following exceptions:

1. The Precedent unit is approximately 181 mm (7.00 in) shorter than an SLXi. See (Figure 2, p. 14).
2. Evaporator opening and mounting bolt locations on front wall of trailer **are not** the same as for Precedent. Please pay special attention to the length restrictions of the mounting bolts on either side. See ().
3. Overall unit height may be different depending on the application. SLXi Domestic Refrigerated Containers (DRC) with intermodal guard applications do not have a top fairing.
4. Unit door opening radius may be different depending on the application. See (Figure 2, p. 14).
5. A foam insulation needs to be installed onto front wall of trailer prior to unit installation. See (“Installing the Foam Insulation,” p. 23) for more information.
6. **IMPORTANT: The factory installed fuel tank air vent must be in place and functional for the Thermo King unit’s fuel system to operate correctly and for the fuel tank to remain in compliance with Federal Motor Carrier Safety Administration specifications (title 49, paragraph 393.67). A plugged or restricted fuel tank air vent can result in premature damage to the fuel pump and could also cause severe damage to the fuel tank. NEVER remove or install any other component in place of the fuel tank air vent.**
7. Fuel supply and return lines on all SLXi units come with “Quick Connect Fittings” as standard. These need to be removed for North America use. See (“Fuel System Fittings,” p. 28).
8. The SLXi DRC has a new fuel tank and does not need to have a bottom panel installed. See (“Installing the Fuel lines – DRC Applications,” p. 28).
9. Priming for this unit is the same as for an SB unit.
Note: SLXi-DRC, like SB, uses a mechanical lift pump, not an electric fuel pump.
10. External Device Connection with LVD (Low Voltage Disconnect). The LVD switch ensures that all SLXi units provide a dedicated device connection point for external devices, while also preventing battery discharge/depletion of the EON battery during unit idle periods. See (“External Device Connection with LVD,” p. 39) for more information.

Trailer Requirements

Front Wall Requirements

⚠ DANGER

Risk of Injury!

The front wall of the trailer must be structurally strong enough to support the weight of the refrigeration unit.

Unit Mounting Hardware

⚠ DANGER

Risk of Injury!

The use of mounting hardware other than specified for installing the refrigeration unit could result in severe damage to equipment, void the warranty, or cause personal injury or death.

Important: The location of the unit mounting bolts in the front wall of the trailer is critical for proper unit installation. See ("Mounting Hardware Requirements," p. 15)

Unit Dimensions

Fuel Tank Mounting

⚠ DANGER

Risk of Injury!

An improperly installed fuel tank could lead to serious injury or death. Consult your trailer manufacturer for specific details on proper fuel tank installation and recommendations.

King Pin Dimensions

NOTICE

Equipment Damage!

The minimum distance from the king pin to the front of the trailer must be at least 1610 mm (63.4 in.) or severe damage to the equipment will result. **VERIFY THIS DIMENSION BEFORE INSTALLING UNIT!** See "Swing Radius and King Pin Requirements"

Important: VERIFY THIS DIMENSION BEFORE INSTALLING THE UNIT. See ("Swing Radius and King Pin Requirements," p.).

Swing Radius Clearance

NOTICE

Equipment Damage!

The minimum clearance required for the swing radius must be 2040 mm (80.31 in.) or severe damage to the equipment will result. **VERIFY THIS DIMENSION BEFORE INSTALLING UNIT!** See "Swing Radius and King Pin Requirements"

Important: VERIFY THIS DIMENSION BEFORE INSTALLING THE UNIT. See ("Swing Radius and King Pin Requirements," p.).

Evaporator Opening Requirements

⚠ DANGER

Risk of Injury!

The front wall of the trailer must be structurally strong enough to support the weight of the refrigeration unit.

Important: The location of the unit mounting bolts and evaporator opening in the front wall is critical. **VERIFY ALL DIMENSIONS BEFORE INSTALLING THE UNIT.**

Note: It may be necessary to relocate the trailer's front corner clearance lights to the corner radius of the trailer to prevent damage.

1. The evaporator opening must be square. The diagonal measurements must be ± 3.0 mm (0.12 in.).
2. The gasket surface around the opening must be at least 76.2 mm (3.00 in.) wide, be flat ± 3.2 mm (0.12 in.) and free of rivets, seams, or bolt heads.
3. The position of the evaporator opening on the trailer front wall should be selected to enable:
 - a. The top of the evaporator to be as close as possible to the inside surface of the Trailer roof, while still allowing the correct installation of the top mounting bolts.
 - b. The top cover of the condenser to be as close as possible, but no higher than the outside surface of the trailer roof. This is to maximize the free space below the unit (C).

Figure 1. Evaporator Opening Requirements Front View

Note: Dimensions shown are in mm.

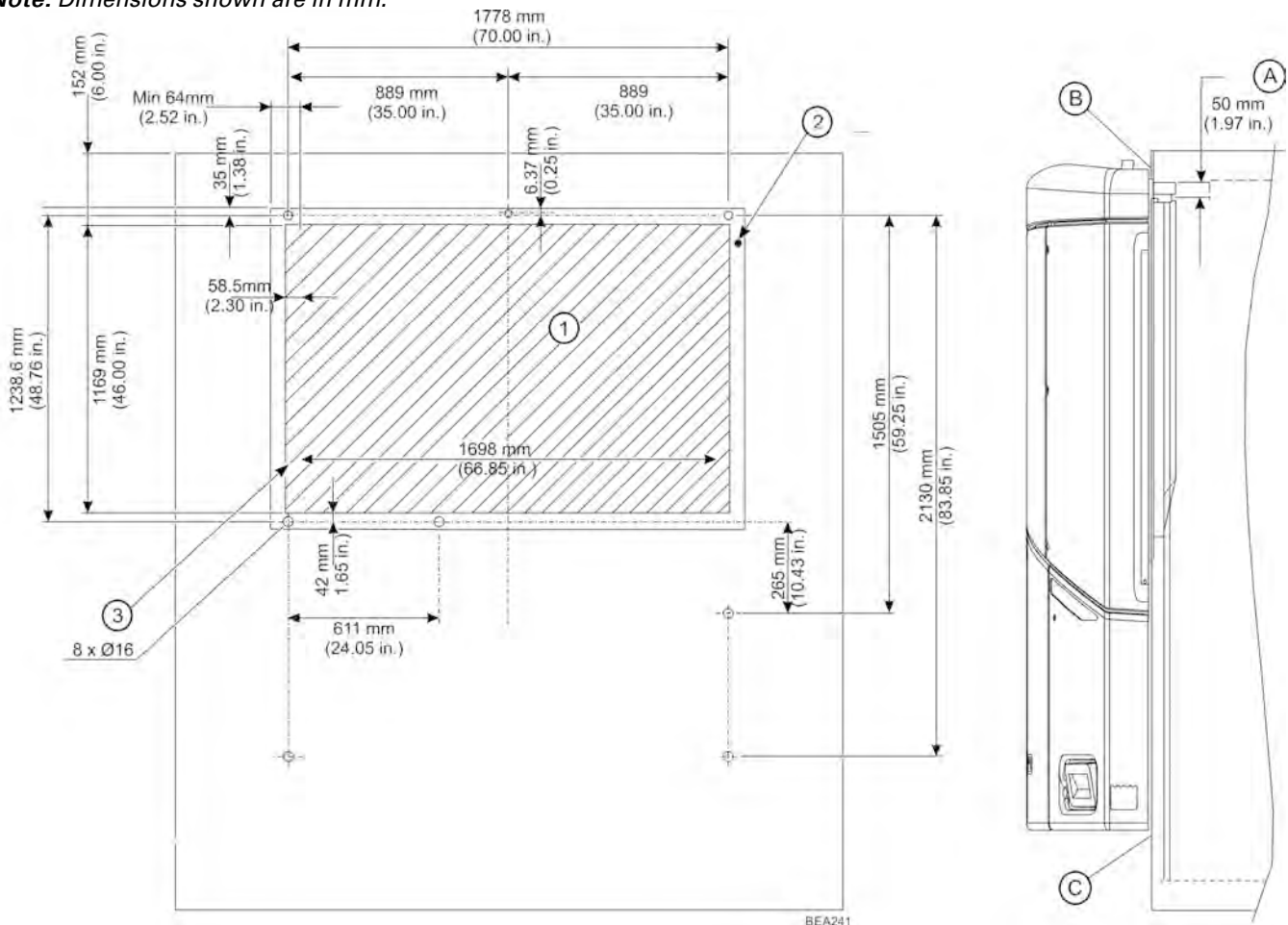

Evaporator Opening Requirements

1.	Unit Evaporator Opening
2.	Gasket
3.	Trailer Cut Out

Figure 2. SLXi Dimensions and Center of Gravity

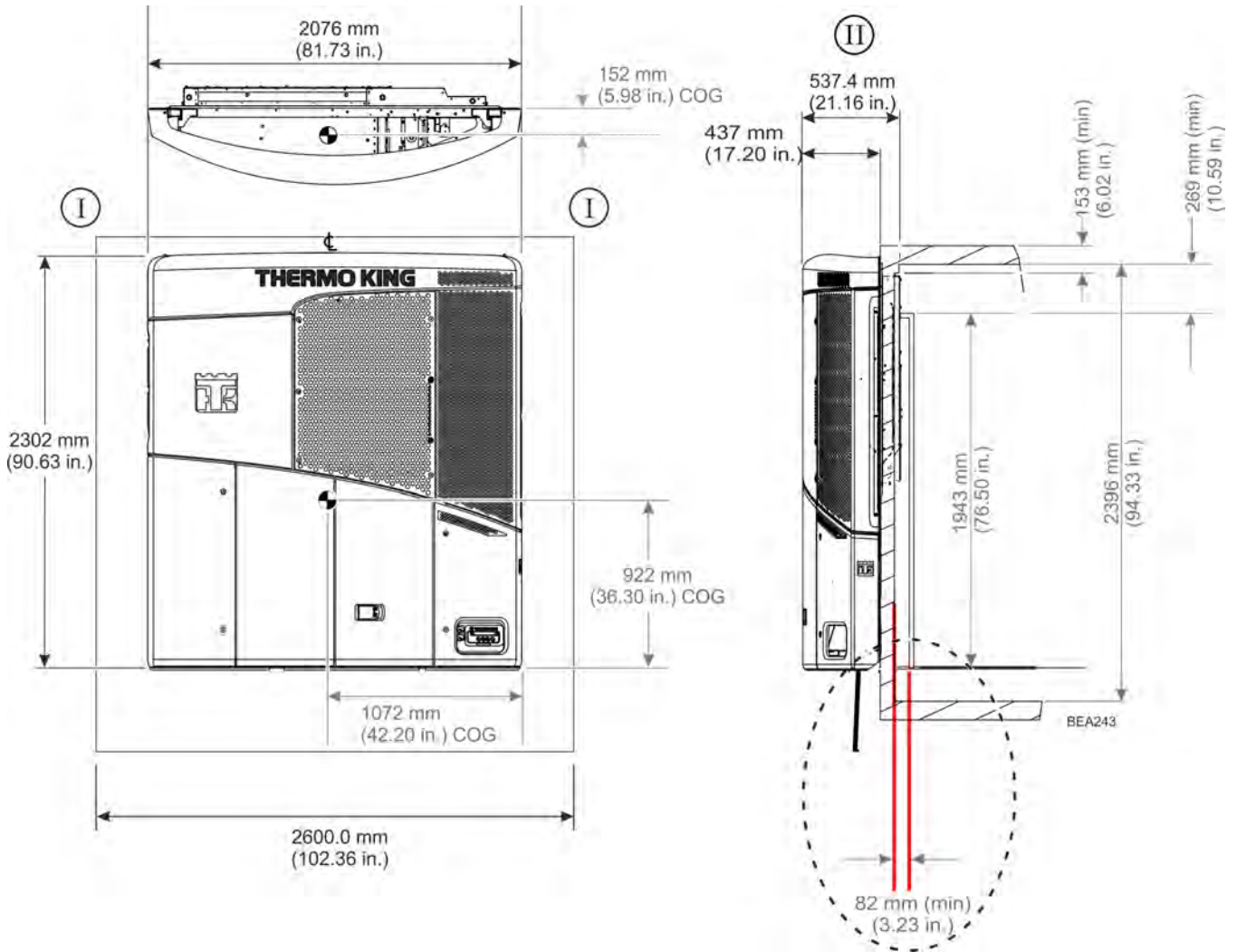

Note: Minimum recommended distance from Trailer wall is shown here.

Mounting Hardware Requirements

Mounting Bolts

⚠ DANGER

Risk of Injury!

Eight mounting bolts must be installed to properly secure the unit to the trailer front wall. Failure to do so could result in severe damage to equipment, void the warranty, or cause personal injury or death.

Note: The location of the unit mounting bolts in the trailer front wall is critical to proper unit installation.

All mounting bolts must be square with the front wall and securely fastened to the trailer wall in such a manner to allow the mounting nuts be torqued to 82 N•m (60 ft. lbs.) from outside the trailer.

See below graphic's regarding the following mounting bolt details:

- Surface of all mounting bolts are to be flat within 2.50 mm (0.10 in.).
- Eight mounting bolts must be installed to properly secure the unit to the trailer front wall.

Mounting Bolt Specifications

⚠ DANGER

Risk of Injury!

The use of mounting bolts other than those specified could result in severe damage to equipment, void the warranty, or cause personal injury or death.

T-bolts, nuts and washers are supplied in the installation kit for properly mounting the unit. Use 1/2 in.-13 UNC - 28 Rolled thread grade 5, medium carbon steel bolts and locking nuts if necessary. All hardware must be zinc plated with dichromate 0.005 mm, minimum thickness and hardness Ro 23-30.

Lifting Bar Dimensions

⚠ WARNING

Equipment Damage and Risk of Injury!

Do not use a forklift to install the unit. This could result in severe damage to equipment, void the warranty, or cause personal injury or death.

⚠ WARNING

Risk of Injury!

The lifting bar and lifting device combined must be able to support minimum weight of 1400 kilos (1 1/2 tons).

⚠ WARNING

Risk of Injury!

Failure to use 2 point lifting bar in accordance with the Thermo King recommendations can result in unit frame distortion.

⚠ WARNING

Risk of Injury!

Under no circumstances must the tension members (e.g. chains) be configured at an angle. This may cause the lifting brackets to fail, causing death or serious injury

Important: Use forged clevis and pins and forged chain links with strength equal to total lift capacity of hoist mechanism and that meet all safety standards.

Figure 3. Lifting Bar Center

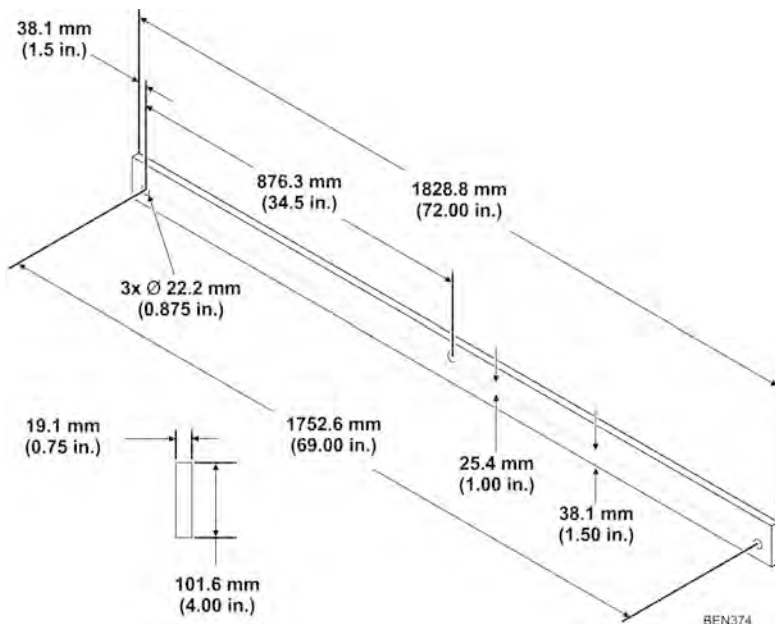
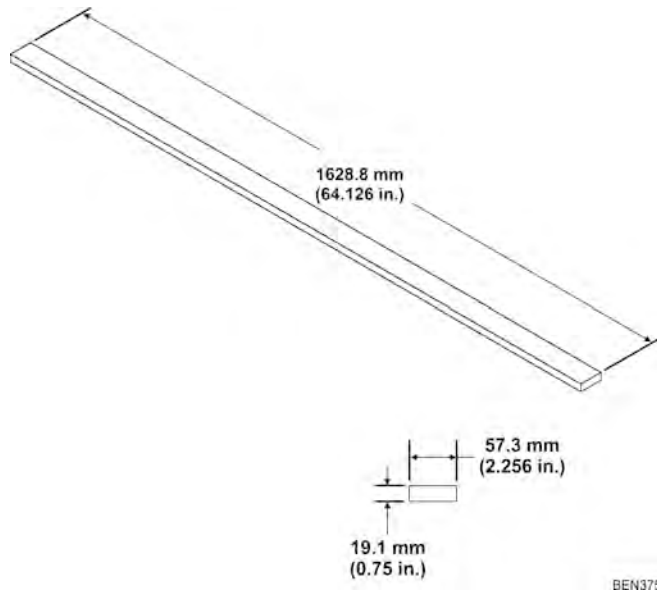

Figure 4. Lifting Bar Base



1.	Forged Clevis Pin
2.	Forged Chain Links

Note: 50.8 mm (2.00 in.) long welds should be made at each end of the bar with additional welds spaced every 76.2 mm (3.00 in.) along the length of the bar. Welding is to be done to both sides of the bar.

Required Tools for Installation

1. Safety Glasses
2. Drill
3. Drill Bits
4. Tape Measure
5. Mechanics Tools
6. Lifting Bar
7. Work Platform (Recommended)
8. Torque Wrench
9. Forged Eyebolts (5/8-11 UNC)
10. Crimping Tool
11. Wire cutters
12. Wire Strippers
13. Heat Gun

Note: *Equipment such as scales, gauges, refrigerant leak detectors, and torque wrenches should be in good working condition and routinely calibrated to assure accurate readings.*

1

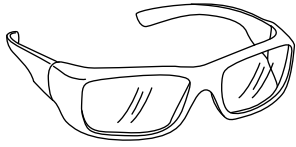

2

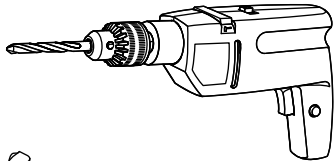

3

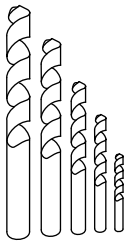

4

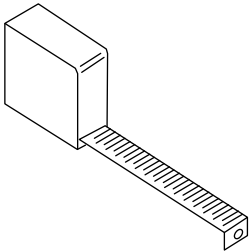

5

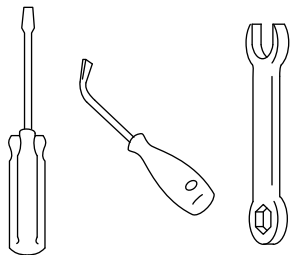

6

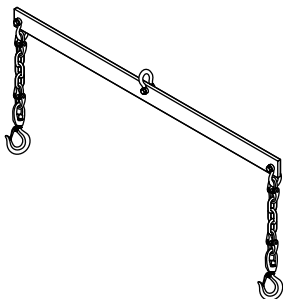

7

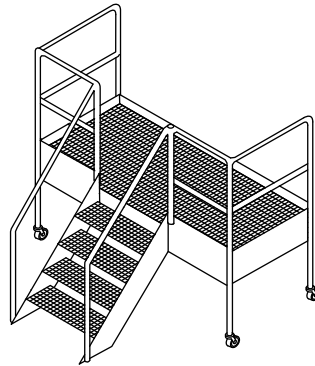

8

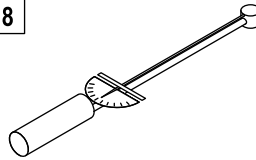

9



10

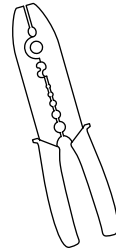

11



12

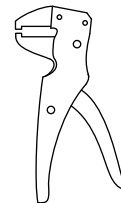

13

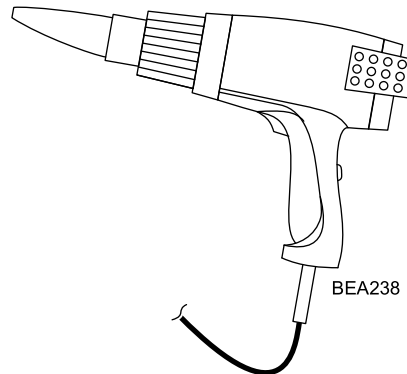

Installation Components – Domestic Refrigerated Container (DRC) Applications

1. Screws
2. Locking Nuts
3. Washers
4. Unit Mounting T-Bolts
5. Self Tapping Screws
6. Clamps
7. Cable Ties
8. Fuel Line Hose (1/4 in. OD, 3/8 in. OD)
9. Fuel Line Fittings (1/4 in., 3/8 in.)
10. Fuel Line Connector
11. M6 Screws, Washers, Locking Nuts
12. Drain Hose Check Valves
13. Rivets (5/32 in.)

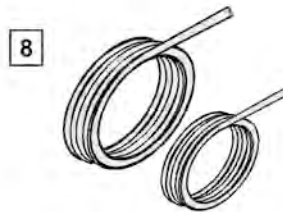
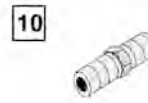
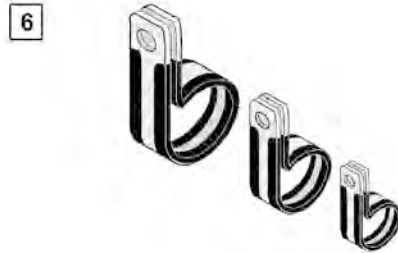
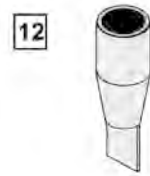
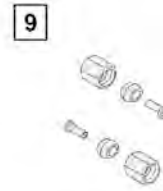
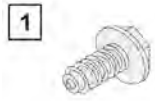

BEN376

Uncrating the Unit

⚠ WARNING

Risk of Injury!

Thermo King requires a 2 point lifting bar to safely lift and install units. A lifting bar can be made from the drawings provided, however, all hardware used to assemble the lifting bar must be DIN 931 class 10.9 (SAE grade 8). The use of hardware other than specified may cause personal injury, severe damage to the equipment and void the warranty

⚠ WARNING

Risk of Injury!

Use only locking hooks to safely lift the unit. Failure to use locking hooks could result in severe damage to the equipment, void the warranty, or cause personal injury or death.

1. Attach lifting bar with forged clevis pins into unit frame forged eye bolts.
2. Remove top bumpers by lifting them straight up.
3. Remove nuts, bolts and washers that hold lower bumpers to the unit frame.
4. Remove nuts, bolts and washers that hold bottom channels and protective plates to the unit frame and carefully lift the unit.

Installing the Foam Insulation

Note: Two foam insulation pads can be found loosely attached to the rear of the unit with band wraps.

The supplied insulation pads must be installed onto the front outside wall of the trailer prior to unit installation. The insulation pads should be positioned in proximity to the mounting bolts as shown.

1. Thoroughly clean the area shown with isopropyl alcohol to remove dirt, grease, wax, etc.
2. Starting at the top, peel approximately 25.4 mm (1.00 in.) of the backing liner from the pad, place pad onto trailer wall and progressively remove liner downward while applying pressure to the foil.
3. Once installed, apply pressure to the remove wrinkles.

Note: Any remaining wrinkles have no effect on performance.

4. The unit is now ready to be installed.

1.	Unit Evaporator Opening
2.	Insulation Pads

Installing the Unit

⚠ WARNING

Equipment Damage and Risk of Injury!

Do not use a forklift to install the unit. This could result in severe damage to equipment, void the warranty, or cause personal injury or death.

⚠ WARNING

Risk of Injury!

Thermo King requires a 2 point lifting bar to safely lift and install units. A lifting bar can be made from the drawings provided, however, all hardware used to assemble the lifting bar must be DIN 931 class 10.9 (SAE grade 8). The use of hardware other than specified may cause personal injury, severe damage to the equipment and void the warranty

⚠ WARNING

Risk of Injury!

Use only locking hooks to safely lift the unit. Failure to use locking hooks could result in severe damage to the equipment, void the warranty, or cause personal injury or death.

⚠ WARNING

Risk of Injury!

Under no circumstances must the tension members (e.g. chains) be configured at an angle. This may cause the lifting brackets to fail, causing death or serious injury

Note: A lifting bar can be made from the drawings shown in () using hardware to assemble the lifting bar of DIN 931 class 10.9 (SAE grade 8)

Note: All nuts that hold the unit to the trailer should be elastic stop nuts (Nylock type) provided in installation kit. They are accessible using an impact wrench with 254 mm (10 in.) extension, ball-type swivel and deep-well socket (Detail 1).

1. Access to Mounting Bolts

- a. Access the top center, top roadside and top curbside mounting holes are normally possible without removing the Unit Top Cover.

Note: Hardware is supplied in the installation kit but not all trailer configurations will permit adding this mounting bolt assembly See ("[Mounting Hardware Requirements](#)," p. 15).

- b. Swing open the entire control box to access the middle and bottom control box side mounting holes.
- c. The lower center mounting hole on the compressor side is accessible through the front access door near the compressor.
- d. The middle and bottom mounting holes on the compressor side are accessible through the road-side access door.

2. Unit Installation

- a. Use the 2 point lifting bar to carefully lift the unit up to the trailer opening.
- b. Attach washers and elastic stop nuts. Torque to 81.3 Nm.

Installing Drain Hoses and Coolant Overflow Hose – DRC Applications

Drain and Overflow Hose Installation

1. Evaporator drain hoses should run down from the unit with no kinks or sharp bends.
2. Secure each hose to the front wall with clamps and screws as shown.
3. Cut off excess hose and attach check valves with supplied bandwraps.

Important: Upper clamp location varies by individual application while lower clamps should be installed 127 mm (5.00 in.) up from the bottom of the drain valves and not so tight as to restrict water drainage.

4. Coolant overflow hose should run straight down the wall with no kinks or bends.
5. Secure the overflow hose to the evaporator drain hose with supplied bandwraps as shown.

Important: The bandwraps must not be so tight as to restrict water drainage.

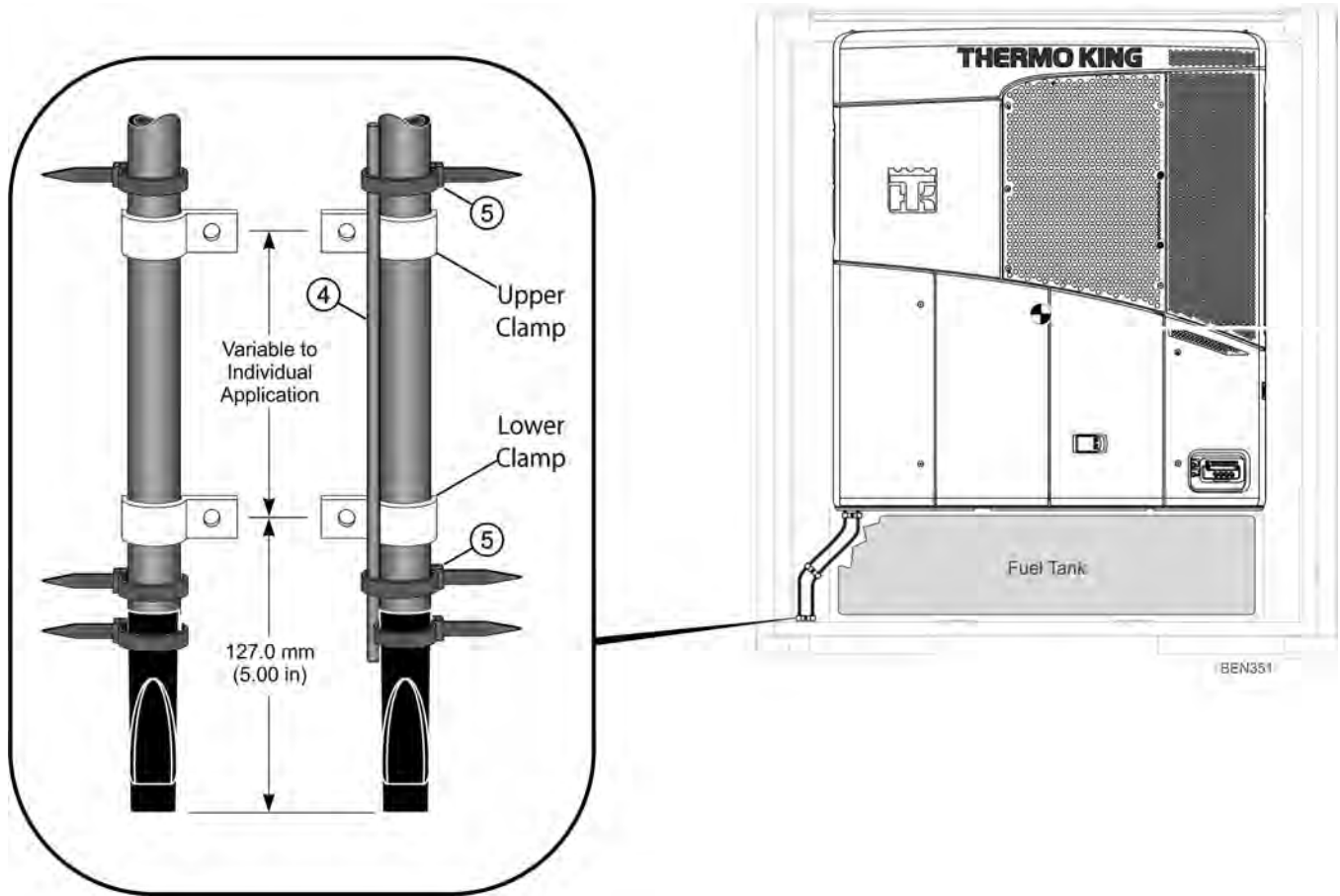

CargoWatch Installation

Sensor Location Recommendations

Note: We recommend that a Single-Temperature Unit has a minimum of two sensors in the cargo area.

1. Sensor #1 located in the evaporator side return opening near unit return air sensor (factory installed).
2. Sensor #2 (Single Temp ONLY If required – refer to your local regulation) recommended location would be
 - Installed in the roof area 66% to 75% of the full length of the cargo area
 - Also one meter towards the middle of the box from the side wall.
 - Sensor must be insulated from the surface of the roof panel using an insulated clamp that allows for air temperature sensing.

Connecting the Sensors

Additional Sensor Connection Procedure

Note: A spare sensor and also 30 red 22-18 AWG splice connectors are supplied with each unit in the installation kit.

1. Locate the desired Harness (Location 1 or 2). See following graphic's.
2. Using the snip pliers, cut the heat shrink so that it is approximately 9 mm long.

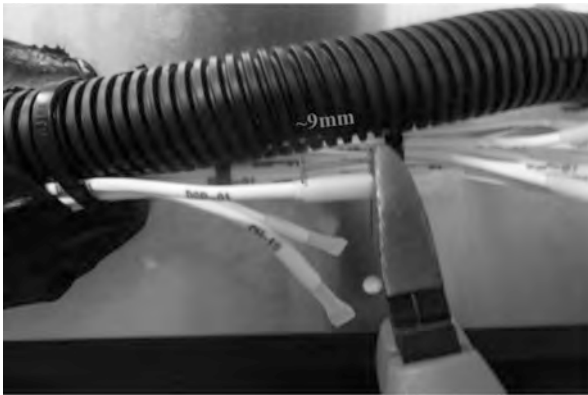

3. Using the wire strippers, correctly adjusted for the wire size & remove the remaining heat shrink.

Note: Using an incorrect size wire strippers may damage the cable.



4. Place the exposed cable through one end of the red 22-18 AWG splice connector (supplied in installation kit).



5. Using a heat gun, apply heat to the left edge of the splice to seal the splice around the insulation of the wire.



6. Once steps 1-6 have been completed, the splice connector is now ready to accept the other cable end. In order to ensure a secure cable connection, please repeat steps 1-6 to connect, crimp and heat the other cable end.



7. Secure sensor in place with appropriate clamps.

Installing the Fuel lines – DRC Applications

Important Installation Requirements

⚠ DANGER

Fire Hazard!

Leaking fuel lines could cause a fire resulting in death or serious injury. All fuel line fittings must be tight and leak free.

⚠ DANGER

Fire Hazard!

Do not route fuel lines with battery cables or electrical wires, as this could cause a fire.

Fuel System Fittings

Each SLXi DRC Unit comes equipped with “Quick Connect Fittings”, however, these fittings are not compliant for certain markets, and must be replaced with compression fittings.

Please follow these instructions carefully.

⚠ DANGER

Fire Hazard!

Leaking fuel lines could cause a fire resulting in death or serious injury. All fuel line fittings must be tight and leak free.

⚠ DANGER

Fire Hazard!

Do not route fuel lines with battery cables or electrical wires, as this could cause a fire.

1. Cut cable tie securing the fuel lines so that they can be routed below the compressor. On SLXi units built from factory, the fuel lines are already connected to:
 - a. the fuel filter fitting (1/4" - fuel out)
 - b. engine fuel fitting (3/8" - fuel in)

Figure 5. Fuel filter fitting (1/4" - fuel out)



Figure 6. Engine fuel fitting (3/8" - fuel in)



2. Identify the 1/4" (fuel out) and 3/8" (fuel in) quick connection fuel lines/fittings.



3. Cut off the "Quick Connect fittings" from the fuel line using cutting tool.



4. Install the provided brass hose fittings over the fuel lines and tighten the compression nut securely.

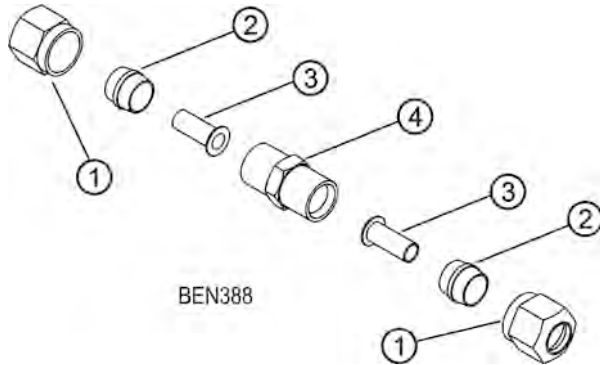

1	Compression Nut
2	Compression Ring
3	Compression eyelet
4	Compression fitting body

- Disassemble the hose fitting as shown above.
 - Take the applicable fuel hose, loosely install the first compression nut and compression ring. Install the compression ring so that the longest sloping face of the ring faces away from the nut.
 - Insert the compression eyelet into the tube flush.
 - Securely push the fuel hose into the compression fitting body.
 - Make sure the fuel hose is completely installed into the fitting body before tightening the compression nut.
- Note:** *It is critical to avoid over-tightening the nut or else the integrity of the compression fitting will be compromised, causing a leak.*
- Take the applicable fuel extension hose and repeat steps a - e with the other side of the compression fitting.
 - Your fuel line now should be extended in order to route to the fuel tank.

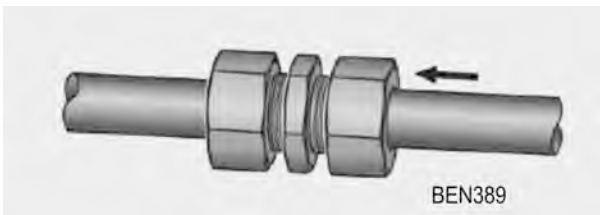

- Repeat step 4 for the second fuel line.
- Route the fuel lines below the compressor and route to the fuel tank.

Fuel Line Installation

Important: Use two wrenches (where applicable) when tightening fuel line fittings to help prevent stripping threads.

Note: All SLXi units come with “Quick connect fittings”. These need to be removed for North America use. See (“Installing the Fuel lines – DRC Applications,” p. 28) for instructions

1. Route the **3/8” FUEL SUPPLY** line down to the fuel tank fitting.
2. Route the **1/4” FUEL RETURN** line down to the fuel tank fitting.
3. Install the provided brass hose fittings over the ends of the fuel lines, tighten the compression nut securely, connect to the 90 degree brass adaptor fittings and into the tank as shown below.

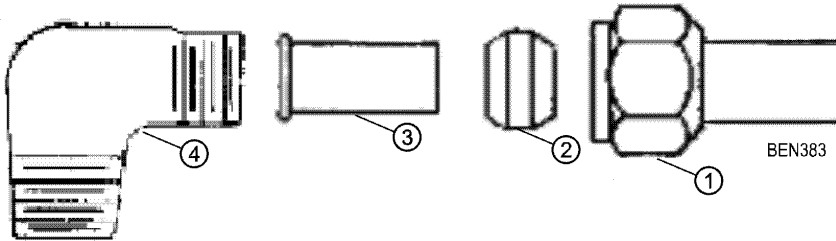

1	Compression Nut
2	Compression Ring
3	Compression sleeve
4	Brass Adapter fitting

4. Remove plastic cap from the fuel vent and point the outlet to the rear of the container.
 - **IMPORTANT:** The factory installed fuel tank air vent must be in place and functional for the Thermo King unit’s fuel system to operate correctly and for the fuel tank to remain in compliance with Federal Motor Carrier Safety Administration specifications (title 49, paragraph 393.67). A plugged or restricted fuel tank air vent can result in premature damage to the fuel pump and could also cause severe damage to the fuel tank. **NEVER** remove or install any other component in place of the fuel tank air vent.

Note: Add a sufficient amount of fuel (1/4 tank) to allow the unit to run for 8 to 12 hours during engine break-in and pre-delivery procedures.

5. Bandwrap the fuel lines to the SLXi frame after routing is complete.

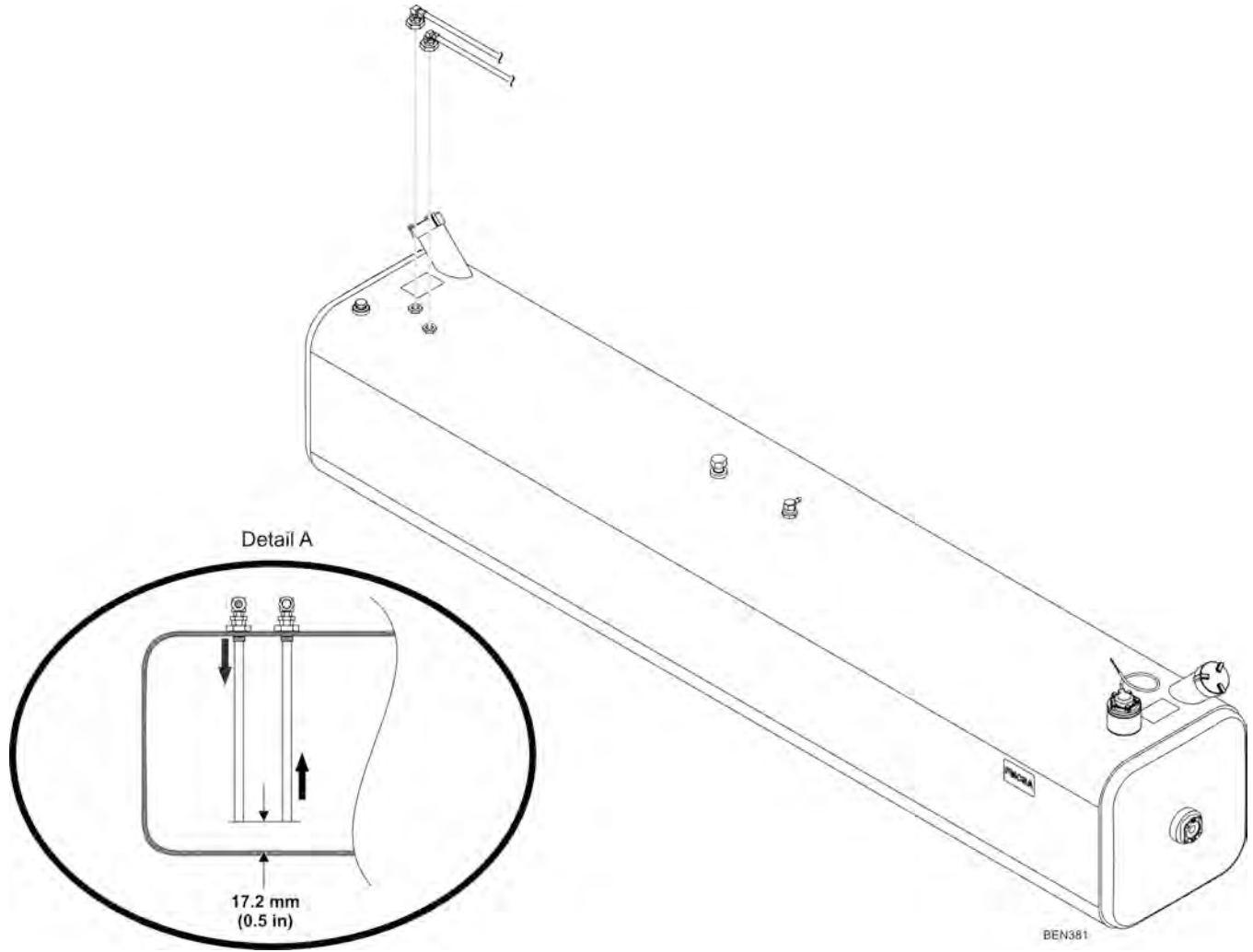

Installing the Fuel Tank - DRC Applications

NOTICE

Equipment Damage!

Do not over tighten the bolts or damage to the tank, container or DRC cage will result!

1. **Rubber Pads** - Wipe the base plates on the container clean where the fuel tank will sit and install the two self-adhesive rubber pads.
2. **Fuel Tank** - Install the fuel tank with the pre-installed rubber pads on the tank facing towards the rear.
 - a. Center the fuel tank being sure it is resting evenly on the two rubber pads (installed previously) onto the base plates.

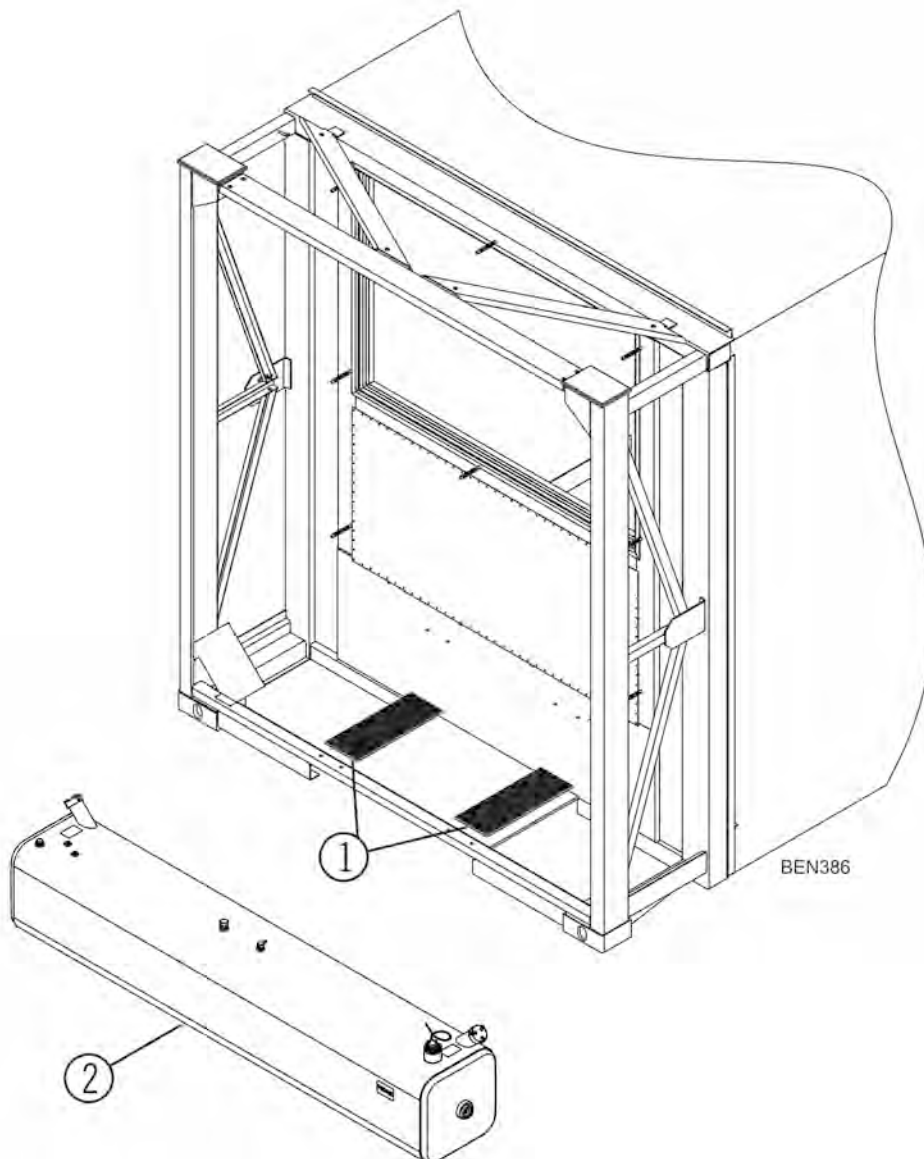



Installing the Fuel Tank - DRC Applications

3. **Tank Straps** - Insert 1/2-13 (M14 x 2) with 1/2 in. (M14) lock washers and 1/2 in. (M14) flat washers through the L-end of each tank strap.

Note: Rubber strips must be in place on the tank straps to prevent the metal straps from chaffing the aluminum tank.

- a. Thread the 4 bolts into the holes in the container body.
 - b. Torque hardware to 81 N•m (60 ft-lb).
4. Align each tank strap end mount with the holes in the lower strap mounting plates:
 - a. Insert 1/2-13 (M14 x 2) x 5.5 in. (140 mm) long bolts with 1/2 in. (M14) lock washer, 1/2 in. (M14) flat washers and spacers through each strap end mount.
 - b. Position this assembly over the holes on the horizontal bar of the DRC cage. Thread the bolts into the holes in the DRC cage.
 - c. Tighten the bolts once to 20 N•m (15 ft-lbs) and stop.
 - d. The straps and rubber strips should only be snug enough to the tank to keep it from moving.

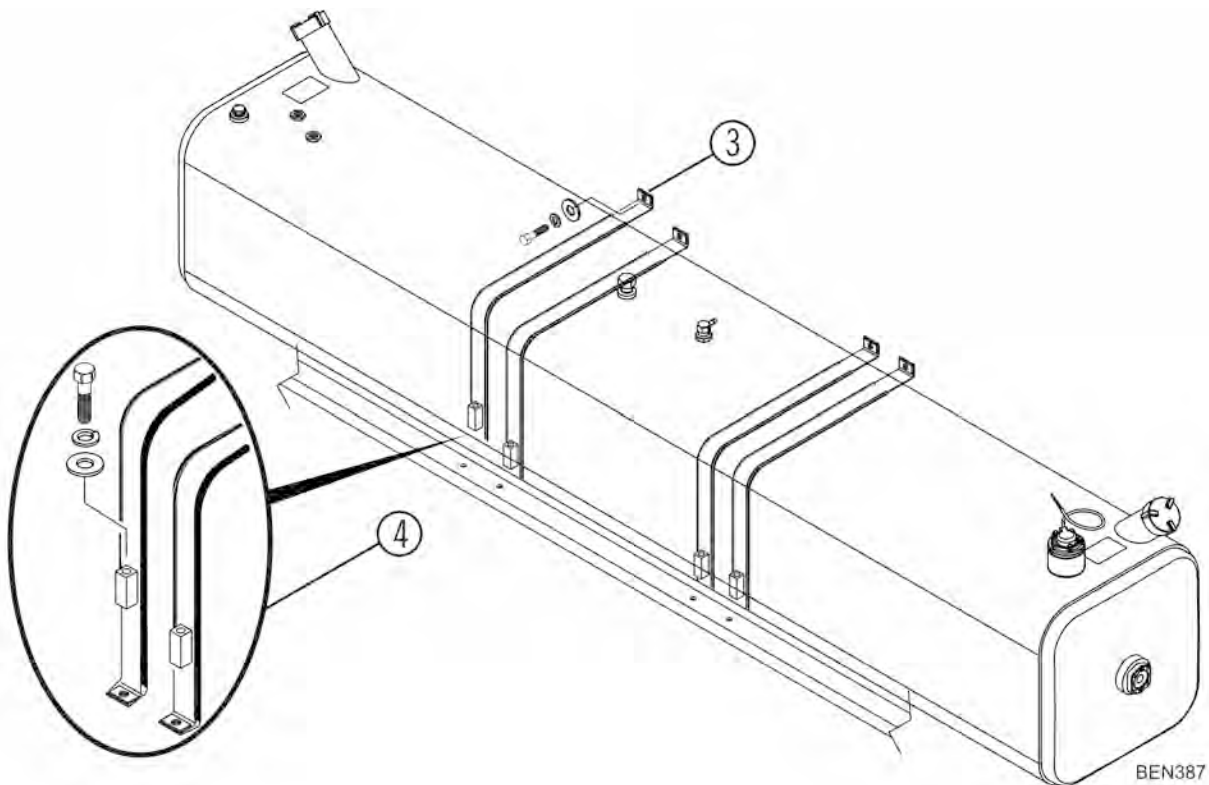

Installing the UFLS Harness – DRC Applications

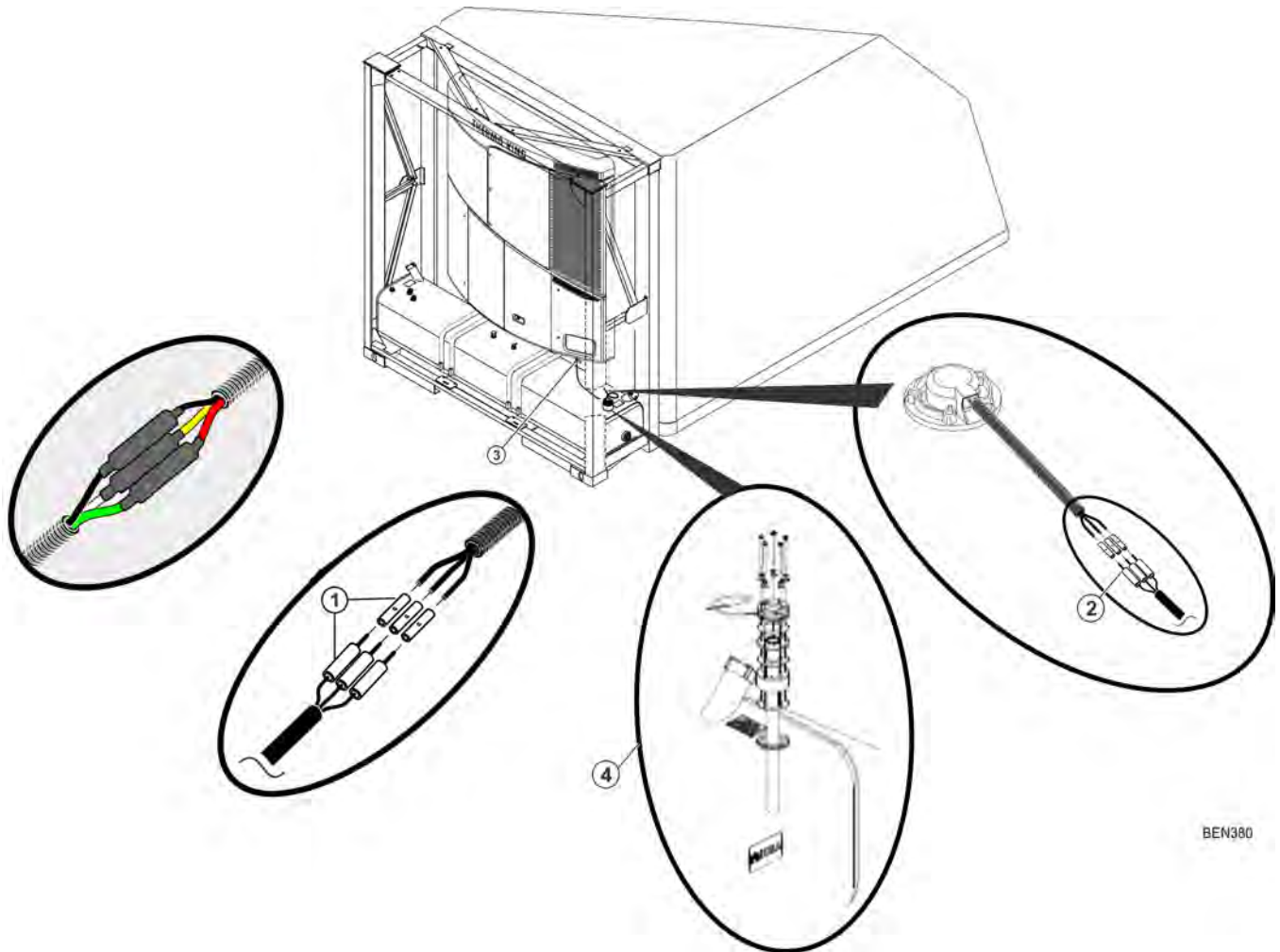

BEN380

“Solid State” Ultrasonic Fuel Level Sensor (UFLS)

Important: All electrical connections of the UFLS harness must be made with the supplied crimp and solder style connectors with separate heat shrink tubing. DO NOT burn the heat shrink. If the heat shrink is burnt, charred, or has bubbles from overheating, the wire connections must be removed and redone correctly.

Interconnect Harness Installation and Routing

⚠ DANGER

Fire Hazard!

Do not route electrical harness together with fuel lines as this could cause a fire resulting in death or serious injury.

1. Attach the interconnect harness to the fuel sensor wires located inside the control box (Item 1).

Connections inside Control Box
BLACK to FUELN-01
WHITE to FUEL-01
GREEN to 8F-01



Installing the UFLS Harness – DRC Applications

- a. Slide supplied heat shrink tubing onto each wire and position them away from joint.
- b. Connect each wire with wire connector and crimp securely.
- c. Solder wires to wire connectors with a soldering gun.
- d. Slide heat shrink tubing over each wire connector and applying heat with a heat gun.
- e. Secure harness inside the control box with tie bands.

UFLS Harness Connections

1. Cut the interconnect harness to length and splice wires to the fuel sensor’s leads (Item 2).

Connections at Sensor
BLACK to BLACK
WHITE to YELLOW
GREEN to RED

- a. Slide supplied heat shrink tubing onto each wire and position them away from joint.
 - b. Connect each wire with wire connector and crimp securely.
 - c. Solder wires to wire connectors with a soldering gun.
 - d. Slide heat shrink tubing over each wire connector and applying heat with a heat gun.
2. Secure any exposed harness with clamps (Item 3).
 3. Install the UFLS sensor assembly in position on the Fuel Tank (Item 4).
 - a. Remove the five screws of the protective cover.
 - b. Install the gasket provided, and then install the Ultrasonic Fuel Sensor assembly in place.
 - c. Secure with the 5 screws/washers provided.

Important: This is a “Solid State” fuel level sensor and the SR-3 Controller must be programmed accordingly to enable the fuel level feature.

Programming the Controller

Programming the SR-3 Controller for Fuel Level

Note: These procedures can also be done through OptiSet™.

Programming Procedures

Note: The Guarded Access Menu is not available if the engine is running.

1. Turn off the engine.
2. Go to the Guarded Access Menu.
3. Scroll down and select the Unit Configuration.
4. Scroll down and select Fuel Level Sensor.

The choices are: NONE, SOLID STATE, or FLOAT.

- **USFLS STYLE** - scroll to SOLID STATE by pressing + key then YES key.
 - **FLOAT STYLE** - scroll to FLOAT by pressing + key then YES key.
 - Fuel Level Percent will now be in the gauge menu.
5. The unit is now programmed, press the exit key.

Connecting the Battery

Note: Please refer to (“Battery Installation and Cable Routing,” p. 7) for all warnings for working with, installing and connecting Batteries

Note: Connect strictly in the following order and disconnect in the reverse order.

The battery mount is located in the frame base under the compressor side of the unit (Detail I).

1. Connect **POSITIVE** battery cable to **POSITIVE** battery post and tighten securely.
2. Connect **NEGATIVE** battery cable to **NEGATIVE** battery post and tighten securely.
3. Ensure that the battery is secure within the clamping system.

External Device Connection with LVD

General Information

NOTICE

Equipment Damage!

Do not connect other manufacturer's equipment or accessories to the unit unless approved by Thermo King. Failure to do so can result in severe damage to equipment and void the warranty.

All SLXi trailer units come fitted as standard from factory with a Low Voltage Disconnect (LVD) Switch to accommodate for 3rd party device connections. The LVD switch ensures that all SLXi units provide a dedicated device connection point for external devices, while also preventing battery discharge/depletion of the EON battery during unit idle periods.

Example of "external devices" which are required to be powered through the LVD switch connection points include:

- Third party telematics
- TouchPrint printer
- TouchPrint dataloggers

Important: All external device connections must be connected through the LVD switch as per instructions detailed below. Failure to connect external devices through the LVD switch may result controller and/or battery related failures being rejected by warranty. The LVD switch acts as a protective medium between the SLXi unit electrical system and external device(s).

The LVD Switch

The LVD switch acts as a protective medium between the SLXi unit electrical system and external device(s).

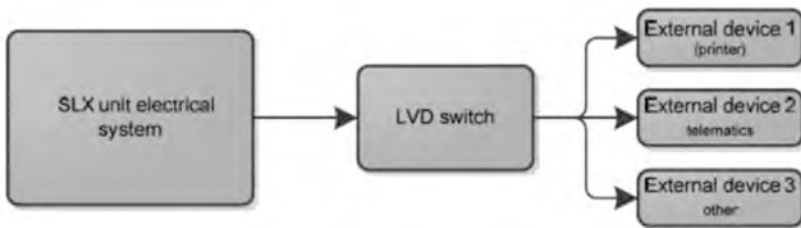

BEN348

The function of the LVD switch is as follows:

- Disconnects power to external devices when battery voltage drops below 12.1V (for longer than 5-7 minutes).
- Automatically resets when system voltage rises above 13V (for longer than 10 seconds).
- Provides connection point in control box for up to 3 external devices.

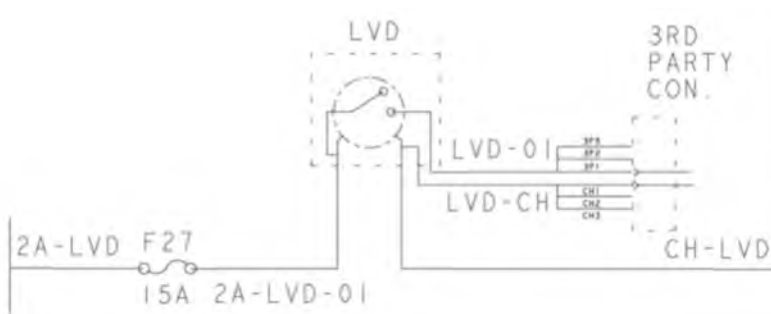

BEN349

- Recommended total maximum current draw from all connected devices combined (At all times, not just when the unit is power down): 2 Amps.

- Excessive current draw due to external devices when unit is powered down will result in the LVD switch disconnecting the output after a short period of time (possibly within hours - depending on total current draw).

Preparing the Unit for device connection

⚠ WARNING

Hazard of Explosion!

When removing battery cables, **ALWAYS** disconnect the negative battery terminal first. Then remove the positive terminal. When reconnecting the battery terminals, connect the positive terminal (+) first, and connect the negative (-) terminal last.

1. Open all the bottom/lower service doors.
2. Open the Control box door.



⚠ WARNING

Risk of Injury!

The unit can start at any time without warning. Press the OFF key on the HMI control panel, place the microprocessor On/Off switch in the Off position and disconnect the battery before proceeding.

Connecting External devices to the LVD Harness

NOTICE

Equipment Damage!

Recommended combined maximum current draw of all externally connected devices (At all times, not just when the unit is powered down): 2 Amps.

Notes:

- All external device harnesses/wiring should be routed through the control box main harness entry point (mouse trap). **Ensure that all wiring is protected and secured from sharp edges and wire chaffing.**
- External devices (unless otherwise recommended by Thermo King) should not be stored/located in the control box.
- All external devices should be fitted with the appropriate (supplier recommended) fusing to protect the device from SLXi electrical system - maximum 2 Amps.
- Example of "external devices" which are required to be connected via the LVD switch connection plug:
 - Third party telematics
 - TouchPrint printer
 - TouchPrint dataloggers

The external device connection point consists of an 8-pin Deutsch connector located inside the control box. The connection procedure is as follows:

1. Detach the male side of the Deutsch Connector from the LVD Harness.
2. Prepare the Positive and negative pins of the external device with 18 gauge male pin sockets (not provided).
3. Insert them into the connector in the appropriate locations listed below.
 - Positive (+ve) Wires: 3P1, 3P2, 3P3 (Shown in RED)
 - Negative Wires: CH1, CH2, CH3 - Shown in BLACK

Note: Make sure that the Positive and Negative pins of the Deutsch Connectors are connected to the corresponding pins.

Note: Wire colours on the female Deutsch Connectors are shown in RED and BLACK for reference only, the wires should be identified by the codes on the wire.

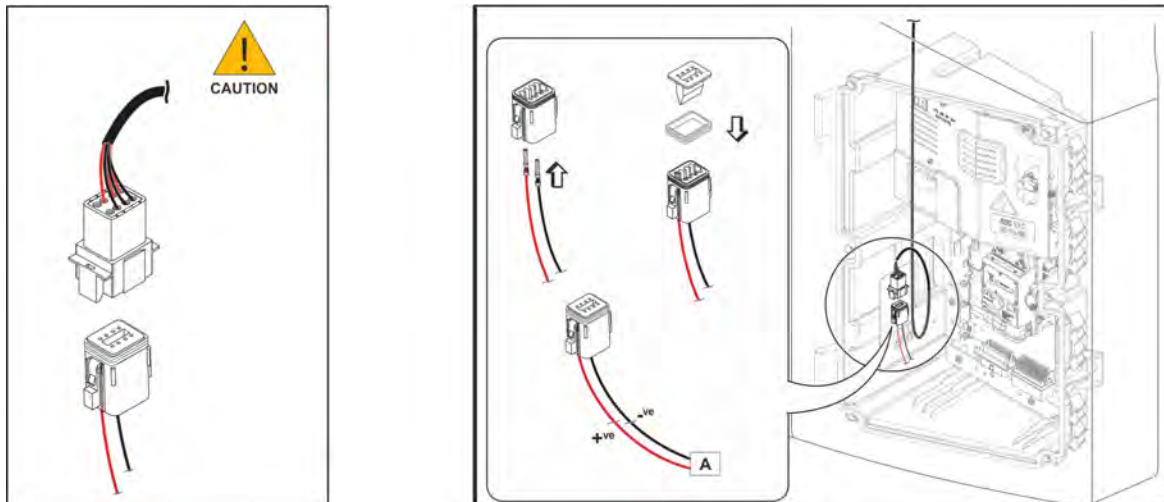

BEN350

4. Re-install the male Deutsch connector to female Deutsch connector located in the control box.
5. Close control box door.



THERMO KING

External Device Connection with LVD

NOTICE

Equipment Damage!

Ensure control box door is correctly/fully closed before reinstalling screws.

6. Re-connect the battery cables.
7. Turn the Unit on at the ON/OFF switch on the Main Unit.

UNIT CHECK LIST

UNIT CHECK LIST

- Visually inspect the unit for transit and handling damage. File claim with delivery carrier.
- Install the unit, fuel tank and lines as outlined in the this Manual.
- Add 15 gallons of fuel to the tank.
- No air gaps between unit and trailer wall.
- Check Doors, Guards, Covers and Grilles are Installed and secure.

BEFORE STARTING THE UNIT

- Check battery and battery cable installation.
- Inspect fuel line routing checking for rubbing, chaffing or laying on hot surfaces.
- Visually inspect the unit for the following: Loose or improperly fitting bolts, brackets, hardware, hose connections, and hose routing.
- Inspect all wiring connections and routing.
- Check defrost drain hoses and check valves (kazoos).
- Check unit mounting hardware for tightness.
- Check compressor and engine mounts.
- Check engine oil level.
- Check condenser and evaporator section for cleanliness and signs of refrigerant leaks.
- Check front bulkhead and air chute if equipped.

START AND RUN UNIT

- Check for proper oil pressure, coolant temperature, oil, fuel, or coolant leaks.
- Check alternator charge.
- Cycle the unit and ensure the unit functions in the correct modes and the mode indicators are working.
- Confirm engine speeds at normal engine running temperature. High Speed and Low Speed per maintenance manual. Check @ 21 C (70 F) box temperature and 21 C (70 F) ambient.
- Set for continuous run with thermostat set point at 0 C (32 F) and run the unit to 0 C (32 F).
- Observe and record refrigerant operating pressures in relation to ambient and box temperatures.
- Verify the readings above are correct for the conditions.
- When box reaches 0 C (32 F) check calibration of thermostat, thermometer and data logger.
- Run unit for 30 minutes at 0 C (32 F). During this period check for correct cycling.
- Reset thermostat to 10 C (50 F).
- Check throttling valve while in the heat cycle.
- Check operation of Modulation system if equipped.
- For Single Temp units perform a controlled check of the refrigerant level. For Multi-temp units check the charge per multi-temp unit procedures.

ALL UNITS

- Initiate and check defrost operation and termination. Check operation and adjustment of damper door and remote fans. Each zone on multi-temp units must be checked for proper operation.
- Set the unit for Cycle Sentry Operation.
- Check for proper operation of all door switches.
- Remove the compartment bulk head(s) if equipped.
- Set the unit for continuous run. Choose a setpoint opposite of ambient temperature. Continue to run the unit with the trailer doors open. Operate the unit until 10 (minimum of 6) hours are shown on the engine run time hourmeter to verify complete break in of the engine.

UNIT CHECK LIST

- Run Pre-trip.

STOP UNIT

- On multi-temp units, leak test interconnecting tubing.
- Check and readjust all belt tensions using TK belt gauge 204-1903 or equivalent frequency tool.
- Check for oil, fuel, coolant, refrigerant, and exhaust leaks.
- Check engine oil and coolant level.
- Check entire unit for loosened hardware and fittings.
- Check and adjust all skin, door and panels for correct alignment and operation.
- Complete the commissioning registration process.
- Release unit.



THERMO KING

Notes

Thermo King – by Trane Technologies (NYSE: TT), a global climate innovator – is a worldwide leader in sustainable transport temperature control solutions. Thermo King has been providing transport temperature control solutions for a variety of applications, including trailers, truck bodies, buses, air, shipboard containers and railway cars since 1938. For more information, visit www.thermoking.com or www.tranetechnologies.com.

Thermo King has a policy of continuous product and product data improvements and reserves the right to change design and specifications without notice. We are committed to using environmentally conscious print practices.